

CES *Imports*

USA Master Distributor for
MANCONI
DESIGN SLICERS BY TRADITION



Approval Pending

SMARTY 300 IX

CES Imports

7250 Santa Fe Dr.
Hodgkins, Illinois, 60525
Tel: (773) 533-3333

Website : www.ces-imports.com | Email : sales@ces-imports.com

Standard equipment

- » Belt transmission
- » Easy to use built-in sharpener
- » Great slicing accuracy
- » Low loading height to reduce the operator strain
- » Carriage with swinging sharpener pusher
- » Reduced foot counter space
- » Removable sharpener, blade cover and slice deflector for easy cleaning
- » Perfect slip grooves for a more performing sliding movement
- » Tilting away carriage
- » Also available with red knobs and sharpener cover

Technical Features

Overall dimensions	609 x 509 x 481 mm (24 x 20 x 19 inches)
Installation area	501 x 409 mm (19.7 x 16.1 inches)
Blade diameter	300 mm (11.8 inches)
Blade speed	250 RPM
Slice thickness	0 to 16 mm (0 to 0.6 inches)
Carriage travel	297 mm (11.7 inches)
Electrical protection	IPX3
Net weight	26.5 kg (58.4 lbs)
Electrical specifications	120 V 60 Hz. Single phase
Cutting capacity	Ø 220 mm – 255 x 220 mm (Ø 8.7 inches - 10 x 8.7 inches)

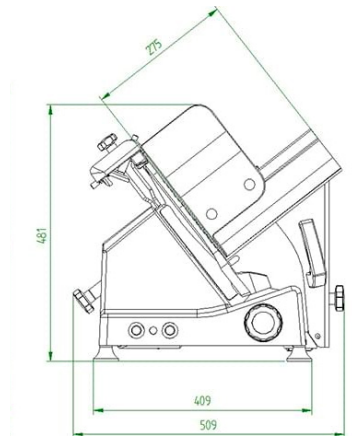
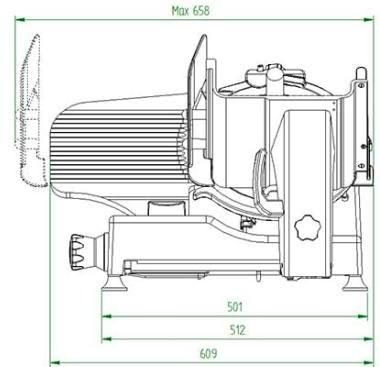

Smarty 300 IX (Black)



Smarty 300 IX (Red)



This device complies with CE safety and hygiene regulations

All information believed to be correct at the time of publishing

Ver. 1.01 20220101