

CES
Imports

USA Master Distributor for
MANCONI
DESIGN SLICERS BY TRADITION

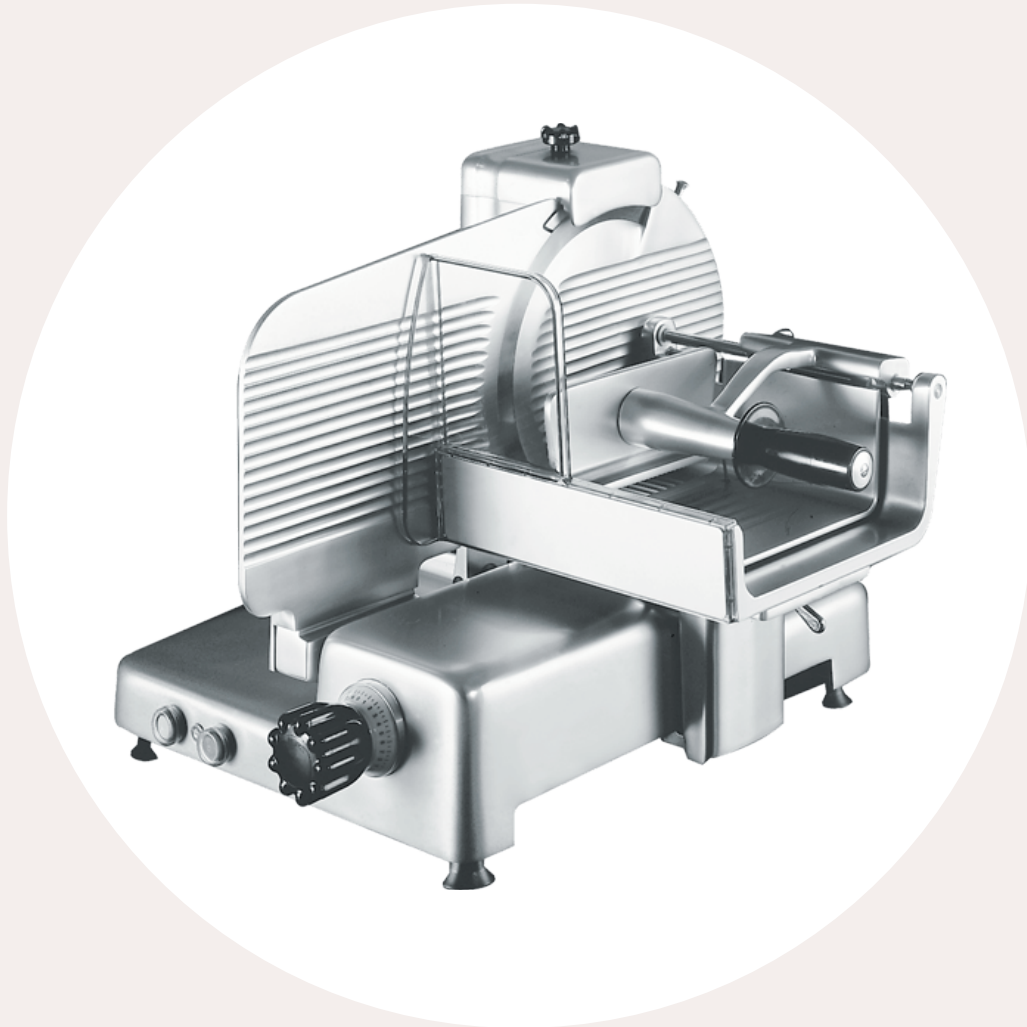

KOLOSSAL 300 VK TC

CES Imports

7250 Santa Fe Dr.
Hodgkins, Illinois, 60525
Tel: (773) 533-3333

Website : www.ces-imports.com | Email : sales@ces-imports.com

Standard equipment

- » Gear box transmission
- » Easy to use built-in sharpener
- » Great capacity and precision in slicing
- » Low loading height; to reduce strain of the operator
- » Ultra smooth, polished aluminum surfaces

and careful slip grooves to reduce friction and simplify cleaning

- » Reduced counter space
- » Removable sharpener, blade cover, and meat deflector for easy cleaning

Technical Features

Overall dimensions	680 x 597 x 515 mm (26.8 x 23.5 x 20.3 inches)
Installation area	521 x 418 mm (20.5 x 16.5 inches)
Working area	680 x 597 x 515 mm (26.8 x 23.5 x 20.3 inches)
Blade diameter	300 mm (11.8 inches)
Blade speed	200 RPM
Slice thickness	0 to 24 mm (0 to 0.9 inches)
Carriage travel	300 mm (11.8 inches)
Electrical protection	IPX3 (Motor IPX5)
Net weight	43 kg (95 lbs)
Electrical specifications	120 V 60 Hz. Single phase
Cutting capacity	Ø 210 mm - 250 x 190 mm (Ø 8.3 inches - 9.8 x 7.5 inches)

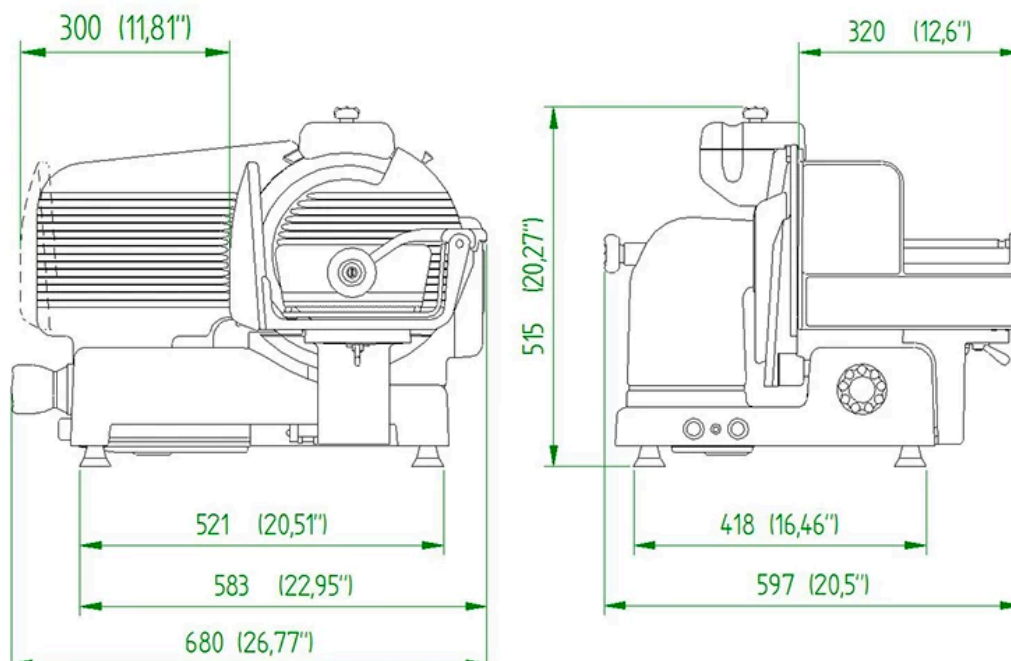

This device complies with CE safety and hygiene regulations

All information believed to be correct at the time of publishing

Ver. 1.01 20220101